

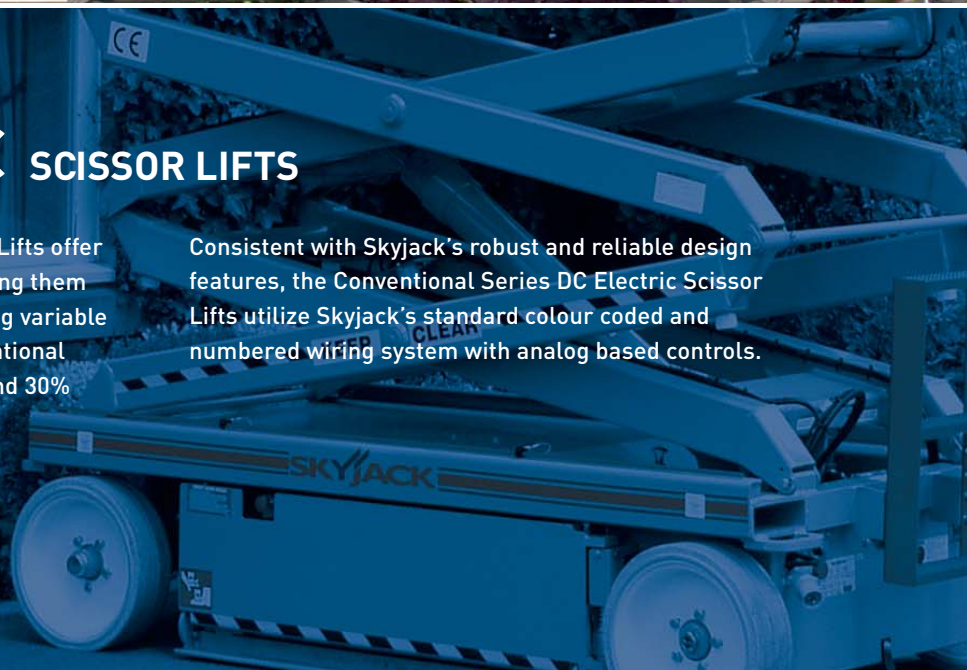

CONVENTIONAL SERIES DC Electric SCISSOR LIFTS

The Conventional Series DC Electric Scissor Lifts offer high capacity and large platform areas, making them suitable for any on-slab application. Featuring variable speed rear wheel hydraulic drive, the Conventional Series offers working heights up to 11,9 m and 30% gradeability.

Consistent with Skyjack's robust and reliable design features, the Conventional Series DC Electric Scissor Lifts utilize Skyjack's standard colour coded and numbered wiring system with analog based controls.



CONVENTIONAL SERIES DC Electric Scissor Lifts

Specifications	SJIII 4626	SJIII 4632
A Work Height	9,9 m	11,8 m
B Raised Platform Height	7,9 m	9,8 m
C Lowered Platform Height	1,1 m	1,2 m
D Overall Width	1,2 m	1,2 m
E Overall Length	2,3 m	2,3 m
F Stowed Height (Rails Up)	2,1 m	2,2 m
G Stowed Height (Rails Down)	1,8 m	1,9 m
H Platform Width (Inside Dimension)	1,1 m	1,1 m
I Platform Length (Inside Dimension)	2,1 m	2,1 m
Extension Deck (Roll Out)	1,2 m	1,2 m
Ground Clearance (Stowed)	8,9 cm	8,9 cm
Ground Clearance (raised)	1,9 cm	1,9 cm
Wheelbase	1,8 m	1,8 m
Weight	2170 kg	2300 kg
Gradeability	30%	25%
Turning Radius (Inside)	1,2 m	1,2 m
Turning Radius (Outside)	2,4 m	2,4 m
Lift Time (With Rated Load)	54 sec	59 sec
Drive Speed (Stowed)	3,2 km/h	3,2 km/h
Drive Speed (Raised)	1.1 km/h	1.1 km/h
Maximum Drive Height	Full Height	Full Height
Capacity (Overall)	454 kg	317 kg
Maximum # of Persons	3	2

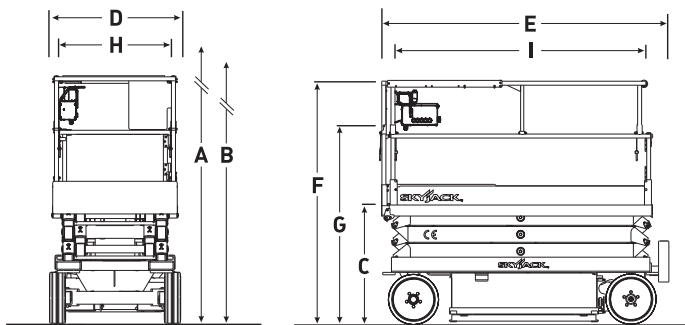

STANDARD FEATURES

- Drivable at full height
- Variable speed, rear two wheel hydraulic drive
- Dual holding brakes
- Proportional controls for drive & lift functions
- 1,2 m roll out extension deck
- 24V DC power source
- Low voltage battery protection
- Analog control system
- Colour coded and numbered wiring system
- Up to 30% gradeability
- Solid rubber, non-marking tyres
- Pothole protection system
- Wiring for AC outlet on platform
- Tilt alarm with drive & lift cut-out
- Overload sensing system
- Lowering warning system
- Operator horn
- Hinged railing system
- Half height spring hinged gate
- Lanyard attachment points
- Forklift pockets and tie down/lift lugs

OPTIONS†

- Flashing light
- 1,83 m powered extension deck (except 4632)*
*adds 60 kg to unit weight and capacity remains the same
- Shop airline to platform
- 250 Ah batteries
- Full height spring hinged gate
- All motion audible alarm
- Pipe racks
- Drywall/board carrier

† Capacities, and machine weights may differ when options are added

Skyjack UK

Unit 1, Maes-y-Clawdd
Maesbury Road Industrial Estate
Oswestry, Shropshire, SY10 8NN
Tel: +44 1691 676235
Fax: +44 1691 676239
Email: info@skyjackeurope.co.uk

www.skyjack.com

Skyjack AB (Sweden)

Marieholmsgatan 2
415 02 Göteborg
Sweden
Tel: +46 31212245
Fax: +46 31212066

Skyjack SAS (France)

Lieudit Les Pretes
22 bis rue de l'avenir
38150 Chanas France
Tel: +33 474 20 30 20
Fax: +33 474 20 58 93

Skyjack Hebebühnen GmbH (Germany)

Wullener Feld 27
D-58454 Witten
Tel: +49 2302 2026909
Fax: +49 2302 2025671

This brochure is for illustrative purpose only and based on the latest information at the time of printing. Skyjack Inc. reserves the right to make changes at any time, without notice, to specifications, standard and optional equipment. Consult the Operating Maintenance and Parts Manuals for proper procedures. CE marked work platforms are in conformance to Machinery Directive 2006/42/EC.